

# Snorkel

# Wildcat® SL 20

## Narrow Slab SCISSORS

### Optional Equipment

- Swinging gate
- AC outlet on platform
- GFCI AC outlet at platform
- D-Ring lanyard attachments
- Operator horn
- Flashing light
- Battery condition indicator
- AC generator
- EE rating
- 240 Amp/hr battery

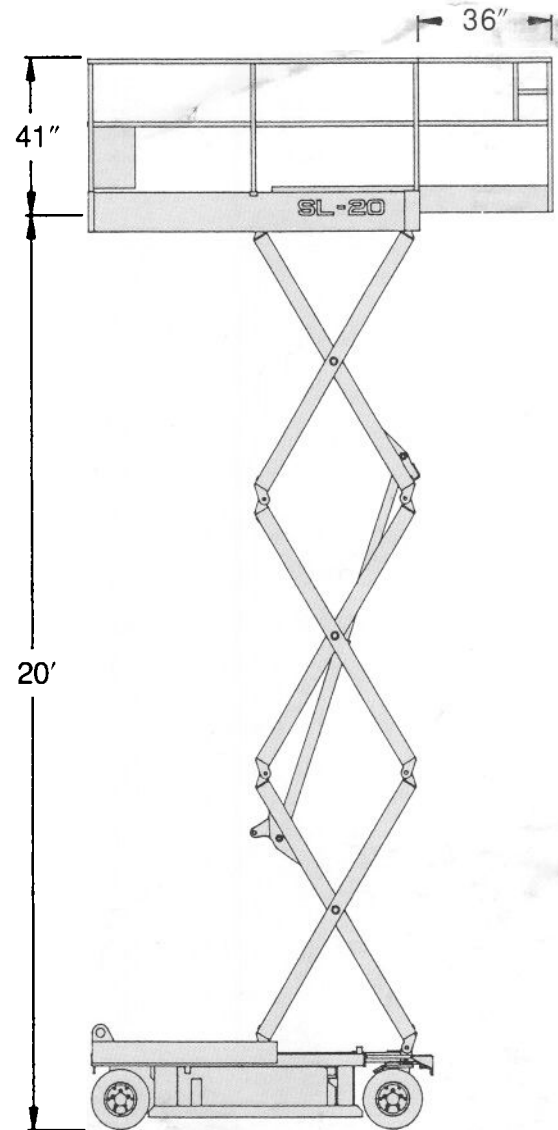
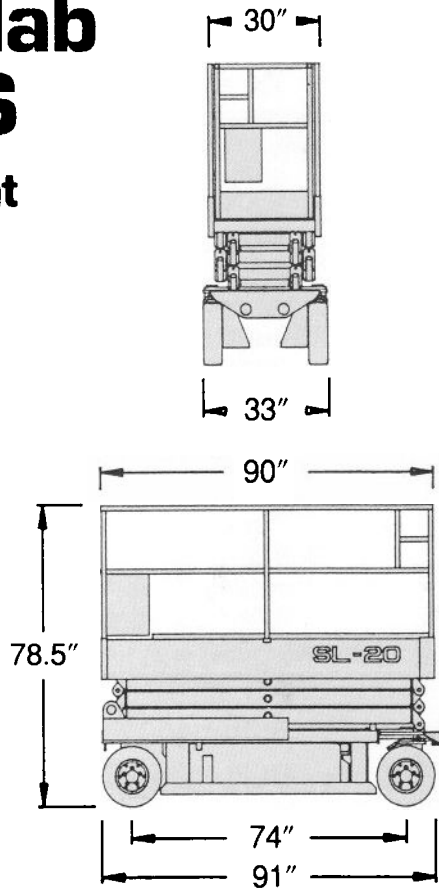

**DANGER:** Models described in this brochure are NON-INSULATED and do not provide electrocution protection from contact with or close proximity to energized conductors which is pointed out on decals and placards attached to the machine.

Only qualified and trained operators are to be authorized to use and operate a work platform.

Aerial work platforms must be elevated only on a firm, level surface.

Products in this brochure comply with applicable ANSI Standards. This literature is for illustrative purposes only. Consult Operating/Maintenance and Parts Manuals for proper procedures. Specifications may vary and are subject to change without notice or obligation.

# Snorkel

P.O. Box 4065  
St. Joseph, MO 64504-0065  
Phone (816) 364-0317  
Fax (816) 364-0380

# Snorkel

# Wildcat<sup>®</sup> SL 20

The narrow width of these machines allows them to fit through most standard doorways, and the wide variety of standard features makes them ideal for slab-type construction, building renovation, or maintenance work of all types.



## S P E C I F I C A T I O N S

Working height Platform	26'	7.9 m
Height	20'	6.1 m
Capacity*	800 lbs.	363 kg
Size	30" x 90"	76 x 229 cm
Guardrail Height	41"	104 cm
Toeboard Height	6"	15 cm
Stowed Platform Height	37 $\frac{1}{2}$ "	95 cm
Stowed Overall Height	78 $\frac{1}{2}$ "	199 cm
Overall Width	33"	84 cm
Overall Length	91"	231 cm
Wheelbase	74"	188 cm
Turning Radius		
Inside	30"	76 cm
Outside	101"	257 cm
Gradeability		20 %
Drive Speeds		
Speed No. 1 Elevated	0.4 mph	0.6 kph
Speed No. 2 Stowed	1.2 mph	1.9 kph
Speed No. 3 Stowed	2.1 mph	3.4 kph
Platform Lift Speed (3 speed control)		20 sec. minimum
Ground Clearance (Approx.)		
Platform Stowed/Pothole Protector Raised	3 $\frac{1}{4}$ "	8.3 cm
Platform Raised/Pothole Protector Lowered	3 $\frac{1}{4}$ "	1.9 cm
Tire Size		4" x 16"
Type		Solid Rubber
Weight (Approx.)	3,750 lbs.	1,701 kg.
Shipping Cube		
With Guardrails	139 ft. <sup>3</sup>	3.9 m <sup>3</sup>

\*Rated load on roll-out extension deck is 250 lbs. (113 kg)

- Automatically activated pothole protection
- Built-in level sensor interlocks
- Fits through most standard doorways
- 3' roll-out extension
- Joystick control on removeable control console
- Responsive center pivot-type steering
- 3-speed drive/3-speed lift
- Dual wheel drive system
- Motion warning alarm
- 2-wheel parking brakes
- Drivable at full work height
- Swing-out trays for batteries and hydraulics
- Lift out battery tray
- Non-marking tires
- Battery powered with built-in charger
- 60 month factory warranty